

SCOPE: This specification applies to E/M buzzer TRTE-1212P(G)

SPECIFICATIONS:

No.	Item	Unit	Specification	Condition
1	Rated voltage	Vp-p	12	
2	Operating Voltage	Vp-p	6 ~ 15	
3	Max rated current	mA	< 40	Value applying rated voltage (1/2duty square wave resonant frequency.
4	Coil resistance	ohm	140 +/- 14	
5	Sound Pressure Level	dba	85 Min	Value applying rated voltage (1/2duty square wave resonant frequency.10cm
6	Resonant frequency	Hz	2400	
7	Tone		Continuous	
8	Operating Temperature	C	-40 ~ +85	
9	Storage Temperature	C	-40 ~ +85	
10	Weight	g	2	
11	Environmental		RoHS	

DIMENSIONS:

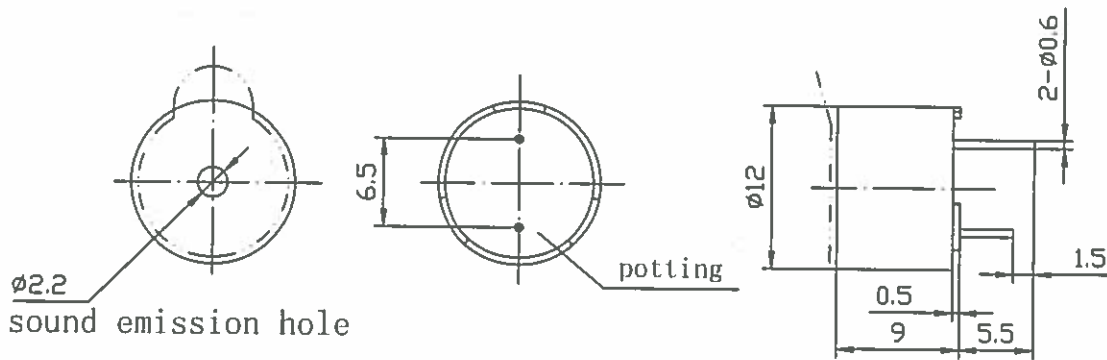

Transducers USA
Confidential and Proprietary

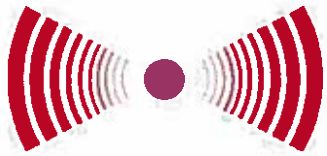

Transducers USA
1400 Howard Street
Elk Grove, IL 60007
Toll Free: 888-921-6400 FAX: 847-956-1950
www.tusainc.com info@tusainc.com

All dimensions are in MM unless otherwise specified

Drawing Number:
TRTE-1212P(G)

E/M External Buzzer

Date:
07/10/2010

THE INFORMATION DISCLOSED HEREIN WAS ORIGINATED BY AND IS THE PROPERTY OF TRANSDUCERS USA, INC. AND EXCEPT FOR USE EXPRESSLY GRANTED TO THE UNITED STATES GOVERNMENT TRANSDUCERS USA, INC. RESERVES ALL PATENT PROPRIETARY DESIGN, USE, SALE, MANUFACTURING AND PRODUCTION RIGHTS THERETO. THIS DOES NOT APPLY TO VENDOR